

LTC - Lambda to CAN

Part Number #61300

Basic Specifications

Inputs / Outputs

- 1 x Bosch LSU 4.9 Lambda sensor
- Power supply voltage 11 V – 16 V
- Power supply current 110 mA typical plus the sensor heater current (heater current is typically 0.5 A – 1 A and up to 2 A on startup)

Communications

- 1 x CAN at 1 Mbit/sec

Physical

- Dimensions 38 x 26 x 14 mm excluding wiring looms and connectors
- Weight 62 grams
- 1 x 4 pin male DTM connector (power/CAN)
- 1 x mating connector for Bosch LSU 4.9 sensor
- Maximum ambient temperature 100 °C

Additional Information

Compatibility

- MoTeC 'Hundred series' ECUs: M400, M600, M800, M880
- Data Loggers: SDL, ADL, ADL2, ACL

PC Requirements

- Windows XP or later
- USB port

Accessories

- MoTeC UTC #61059 (Note: UTC is required, not compatible with MoTeC CAN cable)

User Manual and Software

- The latest versions are available from www.motec.com/downloads



MoTeC's **LTC (Lambda To CAN)** monitors, controls and diagnoses a Bosch LSU 4.9 Lambda sensor, and transmits Lambda readings on a CAN bus. When using LTCs, up to 32 Lambda sensors can be configured on a single CAN bus allowing an ECU or logging device to simultaneously monitor multiple Lambda sensors.

NOTE: MoTeC's LTC is also available in a twin version, LTCD #61301.

Features

- Provides accurate Lambda measurement even when exhaust gas temperature is changing rapidly (heating or cooling)
- Calibrated by the user for a particular sensor using either the initial sensor factory calibration or a free air calibration
- Pre-configured to suit a single LTC unit installation (see page 3 for more details)

Software

- For multiple LTC installations, LTC Manager software allows all LTC units to be simultaneously managed and diagnosed
- The software is used to:
 - configure and calibrate all LTCs on the CAN bus
 - display readings and diagnostics
 - configure CAN transmission addresses
 - control free air sensor calibration
 - update LTC firmware

Dimensions

All dimensions in [mm]

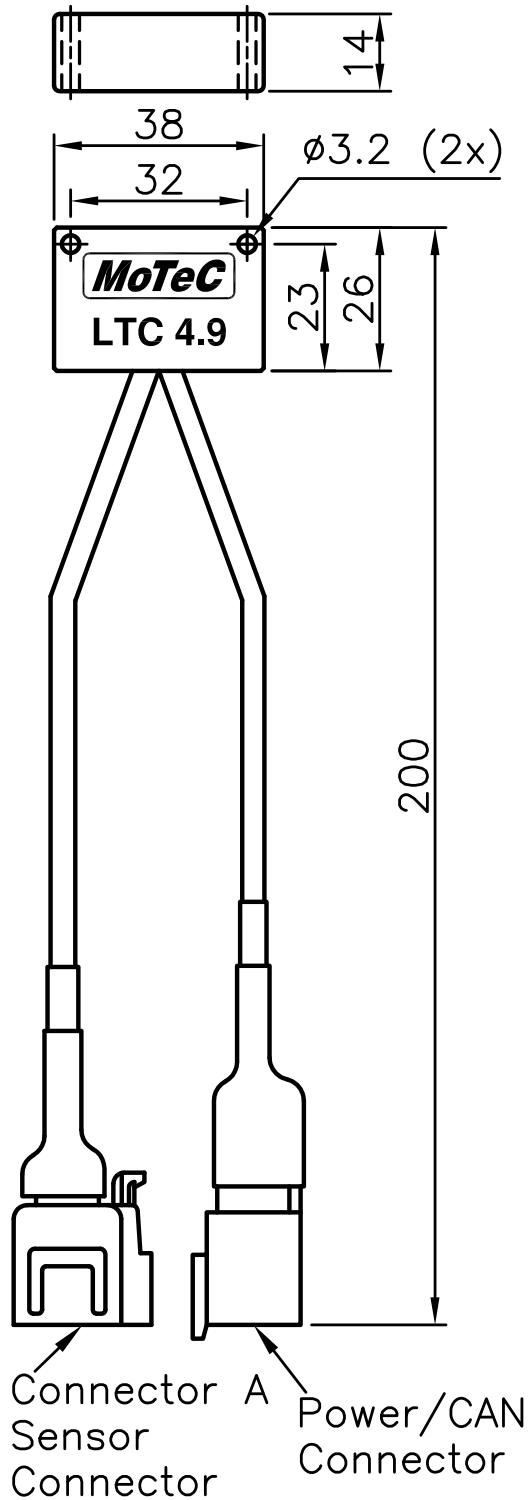

Connectors and Pinout

Connector A

Bosch LSU 4.9 sensor connector
Mating connector: supplied on sensor

Pin No	Wire Colour	Description
1	Red	IPR
2	Yellow	CMN
3	White	Heater -
4	Grey	Heater +
5	Green	IP
6	Black	VS

Power/CAN Connector

DTM 4pin (M) (#68055)
Mating connector: DTM 4pin (F) #68054

Pin No	Wire Colour	Description
1	Black	Battery -
2	Green	CAN Lo
3	White	CAN Hi
4	Red	Battery +

Configuration

MoTeC LTCs come pre-configured to suit a single LTC unit installation. By default, the initial factory sensor calibration is used and CAN address 460.

It is only necessary to use LTC Manager if installing multiple LTC units or if changes to the default settings are required.

Wiring

To connect a single LTC unit, the Power/CAN connector should be wired according to the following table:

LTC pin	SDL pin	ADL2 pin	ACL pin	M400/M600/M800 pin	M880 pin	
Battery -	1	Ground				
CAN LO	2	35	73, 75	5, 7	B24	
CAN HI	3	36	74, 76	6, 8	B23	
Battery +	4	Power 12 V (see tip)				

Tip: To wire the LTC to power connect either to the ignition switch for fast sensor start up or connect to the fuel pump relay to prevent accidental battery drainage

CAN bus wiring

For information on wiring a CAN bus with several LTCs and any number of other CAN devices as in the example below, refer to the relevant device manual.

PC connection

The LTC connects to the USB port on the PC via a MoTeC UTC (USB to CAN). The UTC is plugged into a CAN connector wired into the CAN bus. More information in the LTC manual.

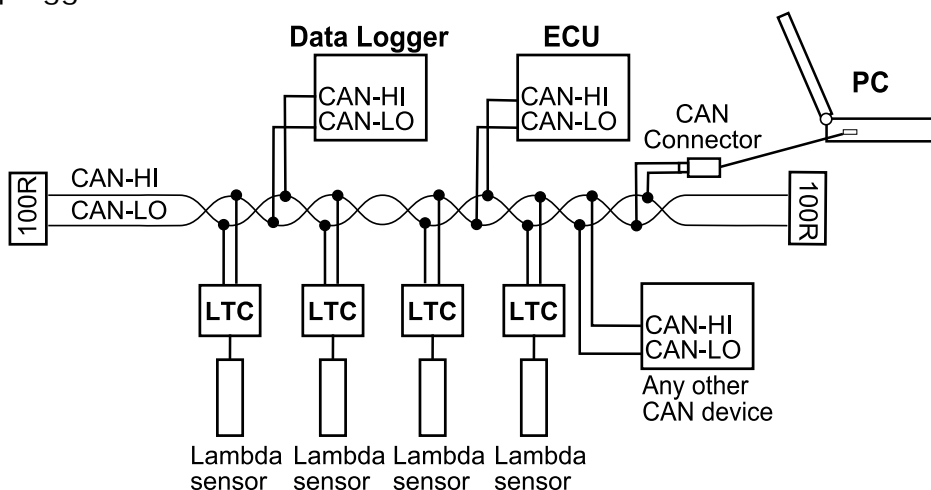

Note: All manuals are available from www.motec.com/downloads