



M130 ECU



MoTeC's unique M1 technology redefines the meaning of customisation, delivering total control without compromise, while highly advanced security strategies make these ECUs ideal for both category managed and unrestricted applications.

The M130 is a Port Injection ECU that offers full control for most modern engines.

► LICENCING

At the time of purchase, an M1 ECU needs to be Licensed for use with a particular Package or a Development Licence.

Packages

An M1 Package is the file that is loaded into an M1 ECU. An M1 Package contains the entire ECU state including the tuning data, worksheets, security and the M1 firmware. M1 Packages themselves are opened and modified in M1 Tune.

• GP Packages

MoTeC offers a suite of General Purpose Packages that allow an M1 ECU to be tuned to any number of applications. The flexibility of these GP Packages enables a tuner to configure the same ECU to very different engine setups, including those with road vehicle systems to maintain, such as air conditioning.

GP Packages are available in variants such as Advanced, Race, Paddle shift and Direct Injection.

• Targeted Packages

○ Public Packages

These are Packages specifically developed in-house by MoTeC engineers for a particular engine or vehicle. In some cases this includes integration with vehicle control systems beyond the engine, for example, stability control and cruise control.

For some targeted applications, the M1 ECU is available in a complete Plug-In Kit which includes any additional hardware that may be required.

○ Partner Packages

These are Packages developed by a MoTeC Partner Developer. It may be based on a Public Package with unique features added by the developer to offer a specific solution.

MoTeC support staff will not provide assistance for these Packages, it will be provided by the Partner.

○ Category Packages

These are Packages developed in-house by MoTeC engineers written specifically for the category, limiting the functionality to the class requirements.

Development Licence

When an M1 ECU is teamed with a Development Licence, it allows users to develop unique control strategies, or make modifications to existing M1 Packages. Using M1 Build software, experienced code writers can tailor the functionality of a single ECU or create a Partner Package for ongoing sales.

▶ BASIC SPECIFICATIONS

Injector

- Peak and Hold or Saturated Injector Outputs: 8
- Max Peak / Hold Current: 12 A / 4 A
- Low Side Injector Outputs*: 2

Ignition

- Low Side Ignition Outputs*: 8

** Unused ignition outputs can be used for other functions like cam or boost control solenoid operation*

Auxiliary Outputs

- Half Bridge Output: 6

Inputs

- Universal Digital Input: 7
- Analogue Voltage Input: 8
- Analogue Temperature Input: 4
- Knock: 2

Data

- CAN Bus: 1
- Logging Memory: 250 MB

Physical

- Dimensions: 107.5 x 127.5 x 38.7 mm
- Weight: 290 g
- Connector: 1 x 34 pin + 1 x 26 pin Tyco

Electrical

- Supply Voltage - Normal Operation: 8 V to 32 V
- Typical no-load supply current: 0.34 A at 13.8 V supply

▶ SECURITY

The M1's advanced security system is based on public-key cryptography - the cornerstone of secure internet transactions - so it is virtually impossible to change the ECU function without authorised permission. Security is enforced by the ECU and protected by a microprocessor with integrated measures to prevent tampering.

A password feature grants different levels of access for different users, e.g. an engine tuner, a drive train tuner and a data analysis engineer. This is also suitable for Control ECU applications. Scrutineering teams can be given access to extra information and are able to lock down selected parts of the ECU, while other team members can be granted access to selected tuning parameters.

▶ FEATURES

- Small and light in robust magnesium enclosure
- Latest generation high performance processor
- Suitable for modern engines with DBW, Cam Control and a CAN bus
- Robust and comprehensive security features
- Flexible tuning software
- Programmable injector drive characteristics
- Programmable digital inputs for Ref/Sync, wheel speeds etc.
- Programmable trigger levels and diagnostics
- All Low Side and Half Bridge outputs have PWM capability
- With Logging Level 3 enabled:
 - Advanced logging features, high speed, multiple logs (with access logins)
 - Logging sets can be partitioned with access logins granting different information for different users from the same device. For example judicial (scrutineering) and team member access

▶ UPGRADES

Logging Upgrades

There are three Logging Licence levels. The level determines the number of channels and sample rates available. Logging Level 1 Licence is diagnostic logging, which comes standard with the product, and includes a fixed log set and sample rates.

- **Logging Level 2 Licence:** This optional upgrade includes 2 log sets, up to 200 channels (including Level 1 diagnostics logging) and a maximum 200 Hz sample rate.
- **Logging Level 3 Licence:** This optional upgrade includes 8 log sets, up to 2000 channels (including Level 1 diagnostics logging) and a maximum 1000 Hz sample rate.

Pro Analysis

This optional upgrade to the professional version of **i2** data analysis software provides advanced mathematics, multiple overlay laps, and unlimited components, workbooks and worksheets.

▶ SOFTWARE

Microsoft Windows™ based software:

- **M1 Tune:** PC Tuning software used to tune fuel and ignition, and set up sensors, outputs and available functions.
- **M1 Build:** PC software used to create a custom software Package with user specific functions.

▶ WIRING AND CONNECTING

Communication (UI)

User communication with the ECU requires an Ethernet connection. A cable providing an Ethernet plug and suitable pin termination for the M1 mating connector can be purchased from MoTeC Dealers.

Inputs

Maximum voltage in inputs not resulting in damage: -30 V to 35 V

Outputs

Maximum current on outputs:

- Low Side Injector outputs: max 3.5 A, RMS 2 A
- Half Bridge outputs: Low Side 12 A, High Side 9 A, RMS 4 A

Wire Gauges

• Battery

- Bat_Pos: all pins should be connected with AWG20, AWG18, or AWG16 wire to a switched battery supply.
- Bat_Neg: all pins should be connected with AWG20, AWG18, or AWG16 wire to a chassis ground or battery negative terminal. 'Star' distribution should be employed to ensure that no ECU ground currents are mixed with actuator ground currents.
- Recommended minimum supply wiring: 1x Bat_Pos, 2x Bat_Neg
- Max supply voltage 35 V

• Outputs

Depending on the current draw for some outputs, a minimum wire gauge is recommended for safe operation:

- Low Side Ignition, Peak Hold Injector, Low Side Injector outputs: AWG20 (ideally) and AWG22 (optional)
- Half Bridge and Full Bridge outputs: these outputs may be used to drive low side actuators, throttle servos, and direct injection pumps. Wire size should be chosen to suit the current requirements of the actuator device. For example, throttle servos and direct injection pumps should use AWG18 or AWG20 wiring
- Half Bridge or Peak Hold Injector outputs provide internal recirculation circuitry, whereas all Low Side outputs do not. In applications where camshaft solenoids and other inductive devices cannot be driven from outputs with internal recirculation circuitry, external recirculation by means of a diode can be installed to prevent slow turn-off of some devices

For further wiring recommendations, contact your local MoTeC representative or MoTeC support (support@motec.com.au).

▶ **M130 PINOUT****M130 Connector A — 34 way**

Mating Connector: Tyco Superseal 34 Position Keying 1 – MoTeC #65044

Pin Number	Designation	Full Name	OE Pin	Function	Description
A01	OUT_HB2	Half Bridge Output 2			
A02	SEN_5V0_A	Sensor 5.0V A			
A03	IGN_LS1	Low Side Ignition 1			
A04	IGN_LS2	Low Side Ignition 2			
A05	IGN_LS3	Low Side Ignition 3			
A06	IGN_LS4	Low Side Ignition 4			
A07	IGN_LS5	Low Side Ignition 5			
A08	IGN_LS6	Low Side Ignition 6			
A09	SEN_5V0_B	Sensor 5.0V B			
A10	BAT_NEG1	Battery Negative			
A11	BAT_NEG2	Battery Negative			
A12	IGN_LS7	Low Side Ignition 7			
A13	IGN_LS8	Low Side Ignition 8			
A14	AV1	Analogue Voltage Input 1			
A15	AV2	Analogue Voltage Input 2			
A16	AV3	Analogue Voltage Input 3			
A17	AV4	Analogue Voltage Input 4			
A18	OUT_HB1	Half Bridge Output 1			
A19	INJ_PH1	Peak Hold Injector 1			
A20	INJ_PH2	Peak Hold Injector 2			
A21	INJ_PH3	Peak Hold Injector 3			
A22	INJ_PH4	Peak Hold Injector 4			
A23	INJ_LS1	Low Side Injector 1			
A24	INJ_LS2	Low Side Injector 2			
A25	AV5	Analogue Voltage Input 5			
A26	BAT_POS	Battery Positive			
A27	INJ_PH5	Peak Hold Injector 5			
A28	INJ_PH6	Peak Hold Injector 6			
A29	INJ_PH7	Peak Hold Injector 7			
A30	INJ_PH8	Peak Hold Injector 8			
A31	OUT_HB3	Half Bridge Output 3			
A32	OUT_HB4	Half Bridge Output 4			
A33	OUT_HB5	Half Bridge Output 5			
A34	OUT_HB6	Half Bridge Output 6			

M130 Connector B — 26 way

Mating Connector: Tyco Superseal 26 Position Keying 1 – MoTeC #65045

Pin Number	Designation	Full Name	OE Pin	Function	Description
B01	UDIG1	Universal Digital Input 1			
B02	UDIG2	Universal Digital Input 2			
B03	AT1	Analogue Temperature Input 1		1k Pullup to SEN_5V_B	
B04	AT2	Analogue Temperature Input 2		1k Pullup to SEN_5V_B	
B05	AT3	Analogue Temperature Input 3		1k Pullup to SEN_5V_A	
B06	AT4	Analogue Temperature Input 4		1k Pullup to SEN_5V_A	
B07	KNOCK1	Knock Input 1			
B08	UDIG3	Universal Digital Input 3			
B09	UDIG4	Universal Digital Input 4			
B10	UDIG5	Universal Digital Input 5			
B11	UDIG6	Universal Digital Input 6			
B12	BAT_BAK	Battery Backup			
B13	KNOCK2	Knock Input 2			
B14	UDIG7	Universal Digital Input 7			
B15	SEN_0V_A	Sensor 0V A			
B16	SEN_0V_B	Sensor 0V B			
B17	CAN_HI	CAN Bus 1 High			
B18	CAN_LO	CAN Bus 1 Low			
B19	SEN_6V3	Sensor 6.3V			
B20	AV6	Analogue Voltage Input 6			
B21	AV7	Analogue Voltage Input 7			
B22	AV8	Analogue Voltage Input 8			
B23	ETH_TX+	Ethernet Transmit +		Ethernet Green/White	
B24	ETH_TX-	Ethernet Transmit-		Ethernet Green	
B25	ETH_RX+	Ethernet Receive +		Ethernet Orange/White	
B26	ETH_RX-	Ethernet Receive-		Ethernet Orange	

► DIMENSIONS AND MOUNTING

Measurements in mm.

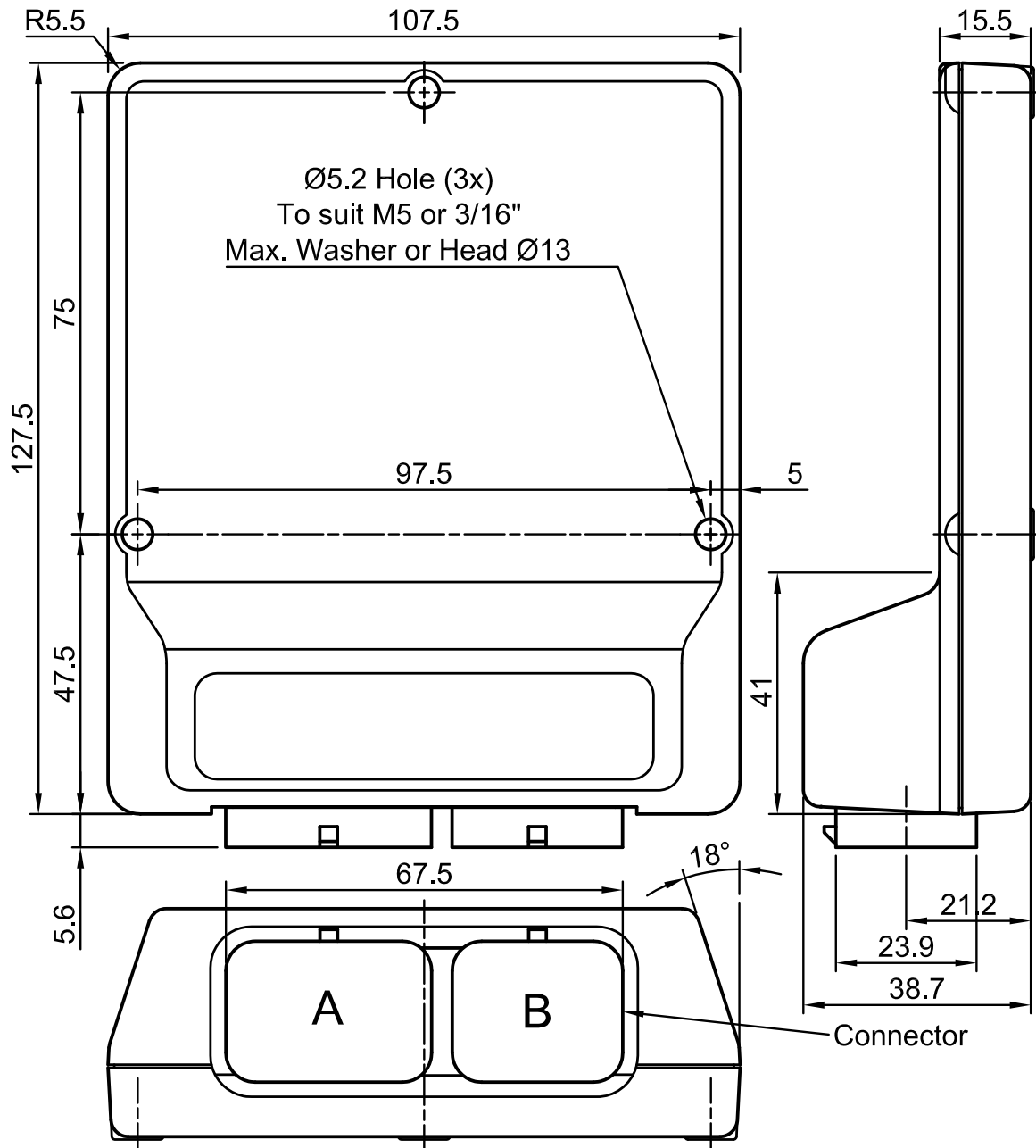

Mounting

The product provides through holes for mounting. See drawing for details. The recommended mounting torque value is 5 Nm. The torque value must not exceed 5.5 Nm.

▶ PRODUCT INFORMATION

Compliances

M1 ECUs are designed for use in a vehicle. As such, this product complies with the following standards:

- CISPR 22 Edition 6 (2008): Information technology equipment - Radio disturbance characteristics - Limits and methods of measurement
- Directive 2011/65/EU: RoHS (Restriction of the Use of Certain Hazardous Substances in Electronic & Electrical Equipment)

Installation

IP Rating (dust or water ingress)

This product should be installed in a protected location where only occasional water splashing occurs and where the exposure to dust does not exceed conditions typical for vehicle installations.

Operating Temperature Range

This product is designed for an internal operating temperature range of -40 °C to 85 °C.

It should be installed in a location with sufficient air circulation and be shielded against thermal emissions from surrounding components.

Vibration Statement

This product is designed to withstand vibrations typical for normal vehicle installations.

It should not be exposed to severe and lasting vibrations. For example, the product should not be installed in solid connection to vibrating components like engines or undamped vehicle structures.

Safety

- For safe operation, use only undamaged.
- Minimal force should be exerted to plug in connectors.
- These devices may output voltages which may constitute a risk to human safety. Appropriate precautions must be taken:
 - At no time operate the device with faulty, bare or exposed wiring.
 - Adhere to the normal supply voltage limits as listed in the **Basic Specifications** section
 - Adhere to wire gauges as listed in **Wiring and Connecting**.

Repair

Do not attempt to open and/or repair the device.

For repairs, contact your local MoTeC representative and return the product via an Authorised MoTeC Dealer.

Disposal



This product should be disposed of in accordance with relevant national regulations for disposal of electronic waste.

It does not contain hazardous materials which might be subject to specific materials regulations.

Manufacturer Information

MoTeC Pty. Ltd.
 121 Merrindale Drive,
 Croydon South,
 VIC 3136, Australia.
 Phone: +61 3 9761 5050
 Fax: +61 3 9761 5051
 Website: www.motec.com.au
 Email: admin@motec.com.au